



Homeowner - Drainage Maintenance Strategy

121 ELMLEAZE, LONGLEVENS

GLOUCESTER, GL2

August 2022

22-OP-1217

Introduction:

The drainage scheme design at the proposed development at the site at 121 Elmleaze, Longlevens, Gloucester in accordance with Part H of the building regulations. Although the network is designed to be self-maintaining the following maintenance strategy is required to be carried out by the building management company. This maintenance and management plan should be incorporated into the sites “Operation and Maintenance Manual” with the as-built drainage system operated and maintained in accordance with the requirements set out in the following section of this report to prevent a reduction in the performance of the drainage system over the lifetime of the development.

Post Development Drainage Management Strategy

We can confirm that the responsibility to maintain the drainage system and any overland flow routes will remain with the landowner.

The Site Manager should ensure that the Maintenance Contractor tasked with carrying out any maintenance works provides a risk assessment and method statement that adopts best practice health and safety policies for maintenance personnel throughout the duration of any maintenance works. Measures may include:

- Ensure the use of safe systems of work and procedures are followed.
- Certificated operatives only to be used for all confined space entry.
- Ensure appropriate PPE is worn at all times including the use of safety goggles, ear defenders and other relevant equipment when using high pressure jetting.
- Erect barriers where appropriate and provide adequate lighting.
- No operations to be carried out by operatives working alone.
- Time maintenance to not conflict with other on-site activities.
- Method statement to be prepared and approved prior to entry into confined space.

The following provides details of the proposed maintenance policies and schedules for each component.

Ref:	Maintenance Item	Required Action	Frequency
01	Surface Drainage Chanel (Aco Channels)	To be monitored and cleaned via jetting when any debris/ silt reduces the cross sectional area by 25% or more. Inspection to include both the channel and silt trap/ gully outlets	Inspection Annually and before/after extreme storm event
02	External Gullies	To be monitored and cleaned with a gully sucker when required.	Inspection Quarterly and before/after extreme storm events
03	Catchpit manholes	To be inspected for debris and integrity of chambers and covers. Any man-entry into manholes should be by trained personnel with adequate personal protective equipment. Approved safety procedures must be followed.	Annually
04	Manholes Generally	To be inspected for debris and integrity of chambers and covers. Any man-entry into manholes should be by trained personnel with adequate personal protective equipment. Approved safety procedures must be followed.	5 yearly
05	Soil Vent Pipes	Rodding points provided to clear blockages via rodding.	As and when needed
06	Rainwater pipe	Clearance of leaves/ debris from guttering	Annually
07	Soakaway Inspection Chamber	To be inspected for debris and integrity of crates and cover.	Inspection Annually and before/after extreme storm event

SUDS and Drainage

Works at:

121 Sandlease,
Longlevens
Gloucester

By

Elevation One
Building Design Ltd
25 Uley Road,
Dursley, Glos
GL11 4NJ



for

Mr Mills

Nov 21

1.0 Introduction

This statement has been prepared by **Elevation One Building Design Ltd** on behalf of Mr Mills.. This statement demonstrates that the proposal is compliant with the Development Plan and Government Guidance and explains the key design and access principles that will be used to develop future details of the scheme.

This report should be read in conjunction with the drawings submitted as part of this planning application.

Maintenance

Like all drainage systems, SuDS components should be inspected and maintained. This ensures efficient operation and prevents failure. Usually SuDS components are on or near the surface and most can be managed using landscape maintenance techniques.

For below-ground SuDS such as permeable paving and modular geocellular storage the manufacturer or designer should provide maintenance advice. This should include routine and long-term actions that can be incorporated into a maintenance plan.

The design process should consider the maintenance of the components (access, waste management etc.) including any corrective maintenance to repair defects or improve performance. A SuDS management plan for the maintenance of SuDS should be prepared.

Table 1 provides a breakdown of typical maintenance requirements. This should include an overview of the design concepts and a maintenance schedule for the scheme to ensure that it continues to function as intended.

In the absence of legislation funding for the adopter to maintain their SuDS may need to be resolved at the start of the development process to ensure that either the local authority, a maintenance company, local residents or the water company have sufficient resources to maintain the system in the long-term.

The level of inspection and maintenance will vary depending on the type of SuDS component and scheme, the land use, types of plants as well as biodiversity and amenity requirements. Further information on maintenance can be found in [The SUDS Manual \(CIRIA publication C697\)](#).

The SuDS scheme is unlikely to be handed over for maintenance until all parties are confident that the scheme is constructed and performs as designed. An interim maintenance plan can be incorporated on larger schemes.



Table 1 Typical inspection and maintenance requirements

Activity	Indicative frequency	Typical tasks
Routine/regular maintenance	Monthly (for normal care of SuDS)	<ul style="list-style-type: none"> • litter picking • grass cutting • inspection of inlets, outlets and control structures.
Occasional maintenance	Annually (dependent on the design)	<ul style="list-style-type: none"> • silt control around components • vegetation management around components • suction sweeping of permeable paving • silt removal from catchpits, soakways and cellular storage.
Remedial maintenance	As required (tasks to repair problems due to damage or vandalism)	<ul style="list-style-type: none"> • inlet/outlet repair • erosion repairs • reinstatement of edgings • reinstatement following pollution • removal of silt build up.



Notes:

1. THE COPYRIGHT OF THIS DRAWING IS VESTED IN ONN POINT ENGINEERING AND IT MAY NOT BE REPRODUCED IN WHOLE OR PART OR USED FOR THE MANUFACTURE OF ANY ARTICLE WITHOUT THE EXPRESS PERMISSION OF THE COPYRIGHT HOLDERS.
2. WORK TO FIGURED DIMENSIONS ONLY.
3. ALL DIMENSIONS IN METRES UNLESS STATED OTHERWISE.
4. ALL PRIVATE DRAINAGE WORKS ARE TO COMPLY WITH THE REQUIREMENTS OF BS 752 BUILDING DRAINAGE AND BUILDING REGULATIONS 2010 APPROVED DOCUMENT H 2002 EDITION. ALL ADOPTABLE DRAINAGE TO COMPLY WITH THE REQUIREMENTS OF SEVERN TRENT WATER AND SEWERS FOR ADOPTION (7th EDITION), INCLUDING THE RELEVANT PROVISIONS OF THE COMBINED ADDENDUM.
5. ALL MATERIALS, UNLESS SPECIFIED OTHERWISE, SHALL COMPLY WITH THE RELEVANT BRITISH STANDARD. SOURCES OF MATERIALS ARE TO BE AGREED WITH THE EMPLOYER'S REPRESENTATIVE/ENGINEER IN ADVANCE OF THE WORKS.
6. ANY DISCREPANCIES IN THE DETAILS SHOWN TO BE REPORTED TO THE EMPLOYER'S REPRESENTATIVE/ENGINEER PRIOR TO CONSTRUCTION.
7. ALL EXISTING SERVICES TO BE LOCATED PRIOR TO THE COMMENCEMENT OF ANY DRAINAGE WORKS WHERE NECESSARY PROTECTION OR DIVERSIONS TO BE UNDERTAKEN TO AVOID CONFLICT WITH THE PROPOSED WORKS.
8. TYPICAL PIPE BEDDING TO DRAINAGE WHERE DEPTH TO SOFFIT IS GREATER THAN 600mm IN LANDSCAPED AREAS AND GREATER THAN 1200mm IN ADOPTABLE HIGHWAYS AND 900mm IN OTHER TRAFFICKED AREAS IS TO BE CLASS S (I.E. 10-14mm GRADED IMPORTED GRANULAR BED AND SURROUND FOR PIPES UP TO 525 Dia AND 20 - 40mm GRADED IMPORTED GRANULAR BED AND SURROUND FOR PIPES GREATER THAN 525 Dia)
9. BACKFILL TO DRAINAGE TRENCHES UNDER CARRIAGEWAYS TO BE TYPE 1 SUB-BASE MATERIAL ELSEWHERE BACKFILL TO BE FREE DRAINING READILY COMPACTABLE MATERIAL FREE FROM RUBBISH AND ORGANIC MATTER, FROZEN SOIL, CLAY LUMPS AND LARGE STONES, TO BE COMPACTED IN LAYERS NOT EXCEEDING 150mm THICK.
10. A FLEXIBLE JOINT SHALL BE PROVIDED AS CLOSE AS IS FEASIBLE TO OUTSIDE FACE OF ANY STRUCTURE INTO WHICH A PIPE IS BUILT, COMPATIBLE WITH THE SATISFACTORY COMPLETION AND SUBSEQUENT MOVEMENT OF THE JOINT. THE LENGTH OF THE NEXT PIPE (ROCKER PIPE) AWAY FROM THE STRUCTURE SHALL BE AS SHOWN IN THE TABLE BELOW.

NOMINAL DIAMETER (mm)	EFFECTIVE LENGTH (m)
150-600	0.6
675-750	1.0
825 AND OVER	1.25

11. WHERE COVER TO PIPE WORK IS LESS THAN 600mm IN PRIVATE AREAS CONCRETE BED AND SURROUND IS TO BE USED.
12. PRECAST CONCRETE MANHOLE RINGS MUST NOT BE CUT UNDER ANY CIRCUMSTANCES
13. IN AREAS OF LESS THAN 1.2m COVER, PIPEWORK IS TO HAVE CONCRETE BED AND SURROUND

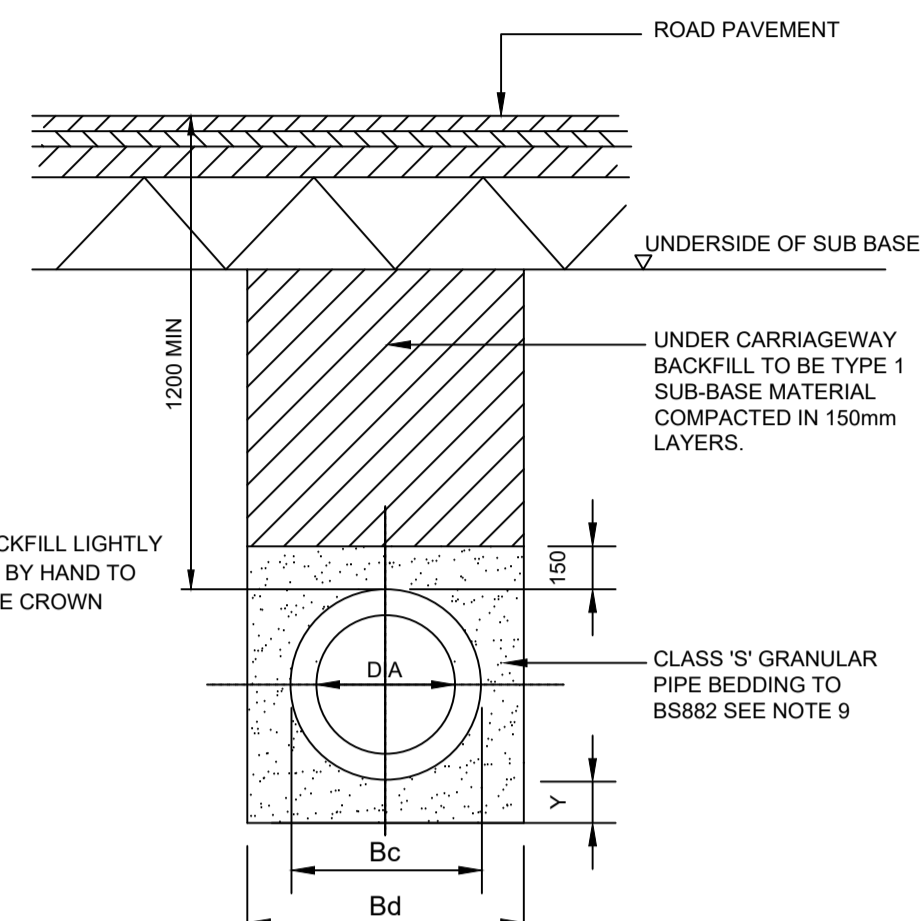

TYPICAL CROSS SECTION THROUGH DRAINAGE TRENCH UNDER CARRIAGEWAY/ADOPTABLE AREAS
SCALE 1:20

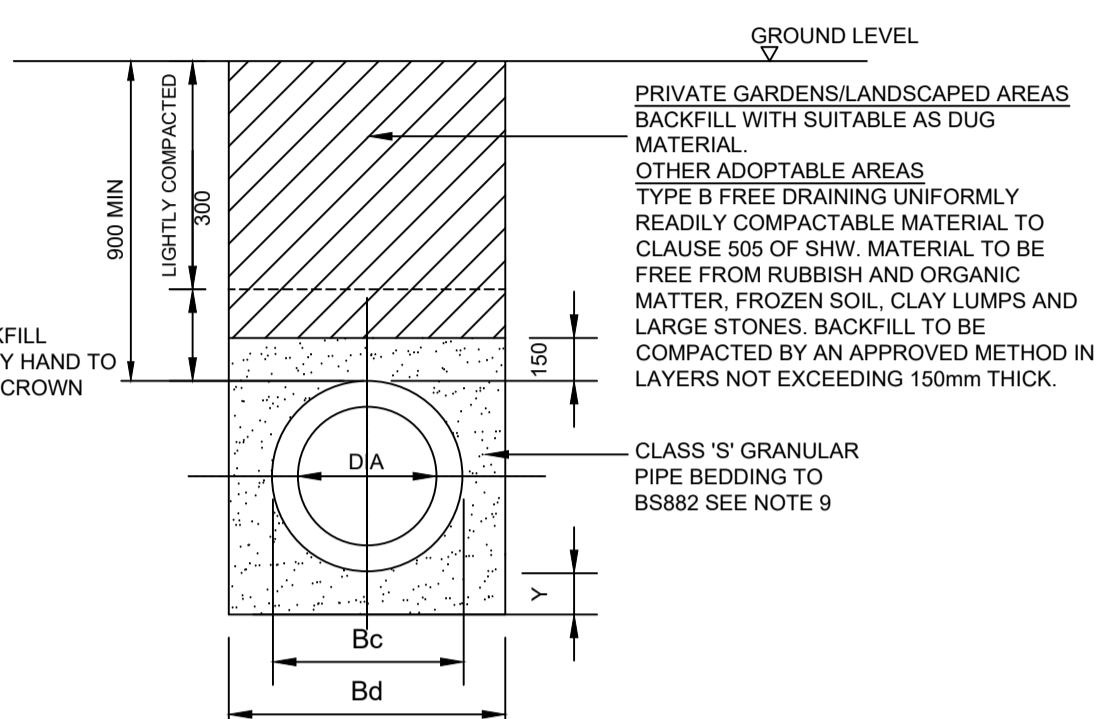

TYPICAL CROSS SECTION THROUGH DRAINAGE TRENCH IN OTHER AREAS
SCALE 1:20

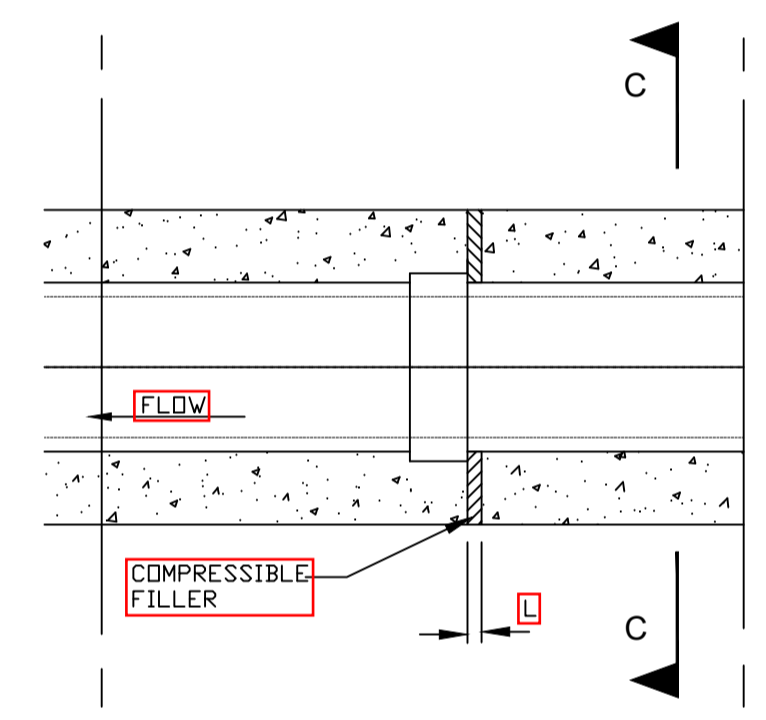

TYPE Z - FLEXIBLE JOINT DETAIL CONCRETE BED AND SURROUND
N.T.S

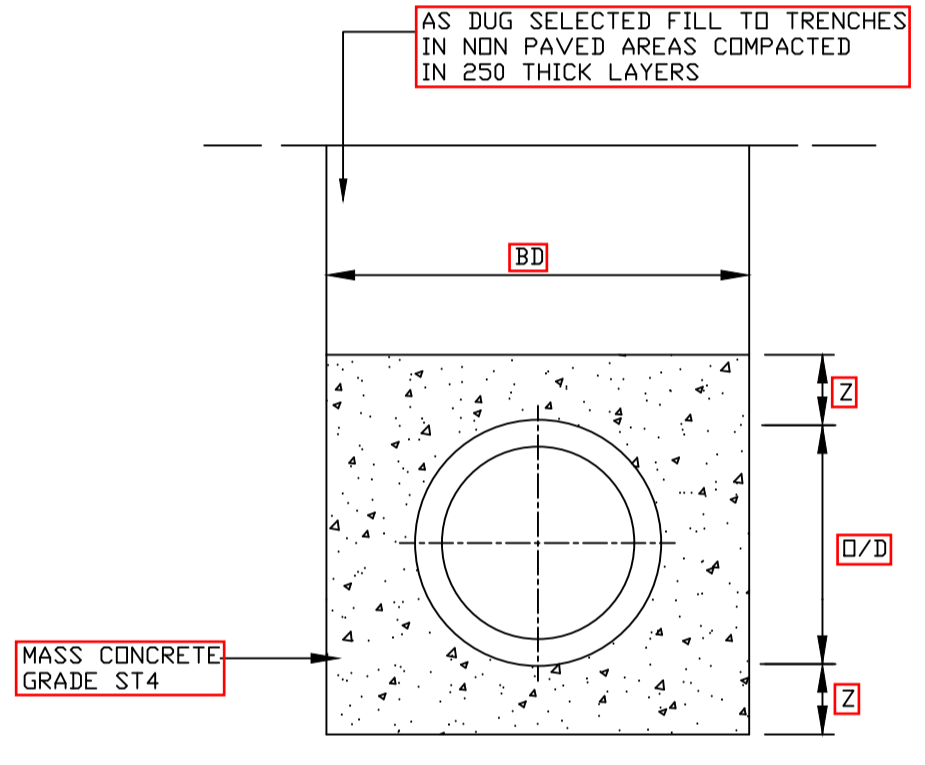

TYPE Z SECTION C-C
SCALE 1:25

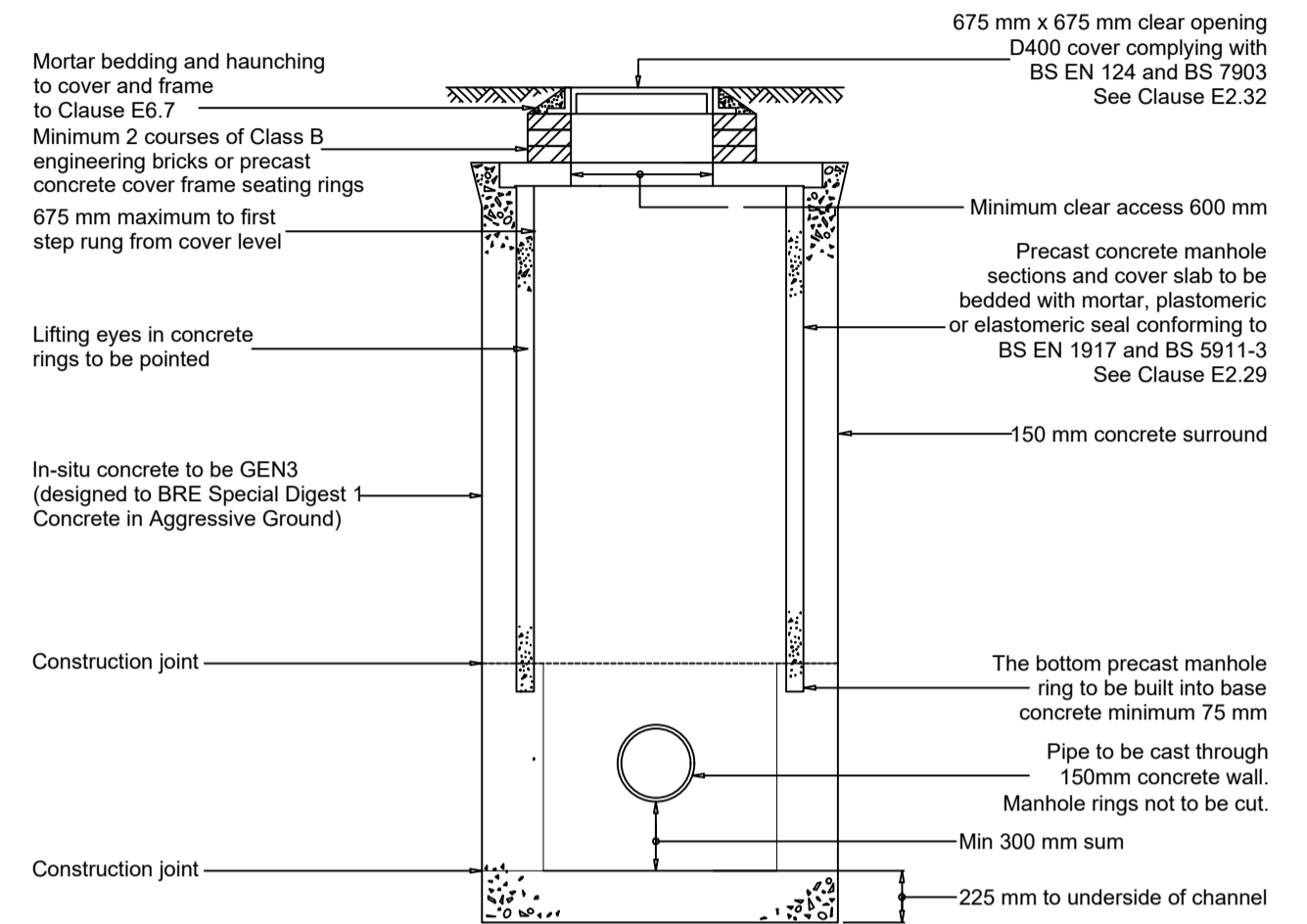

TYPICAL CATCHPIT MANHOLE DETAIL

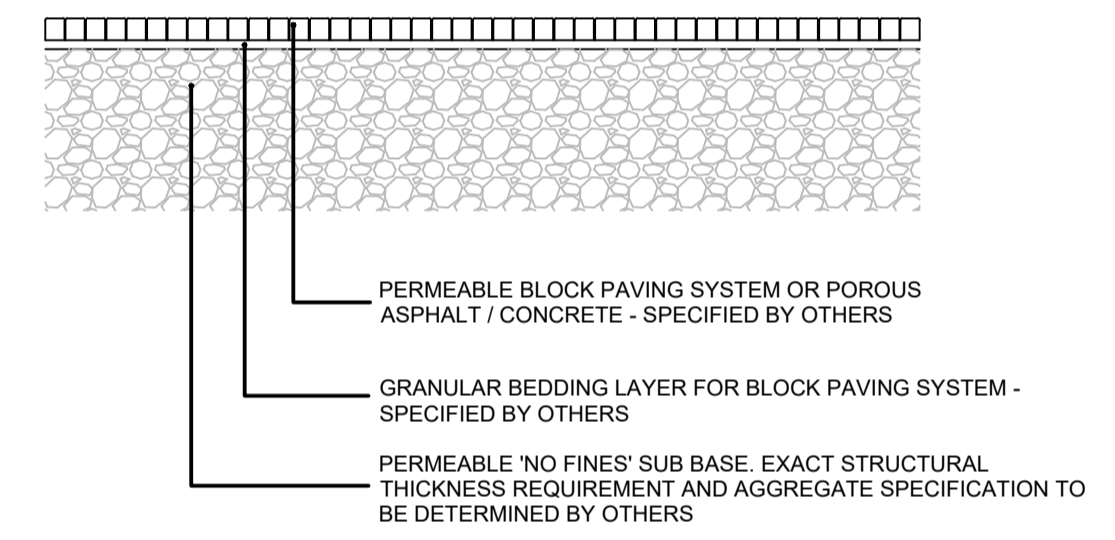

PERMEABLE PAVING CROSS SECTION

FIGURE B.16 TYPICAL INSPECTION CHAMBER DETAIL - TYPE 3 (Flexible material detail)
Maximum depth from cover level to soffit of pipe in areas subject to vehicle loading 3 m, non-entry

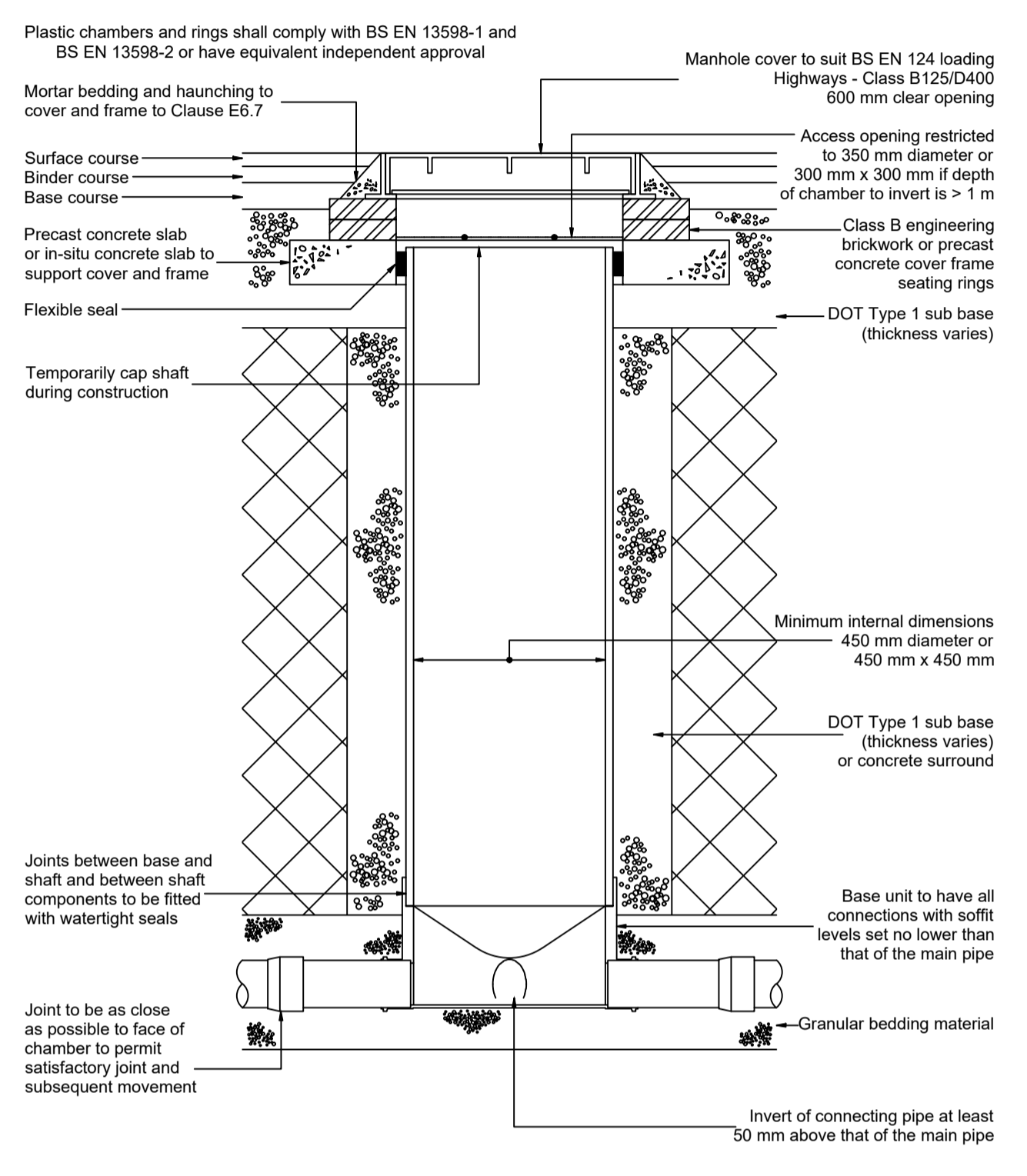

Note: Where the access chamber is in the highway the Highway Authority can have specific requirements

Not to scale

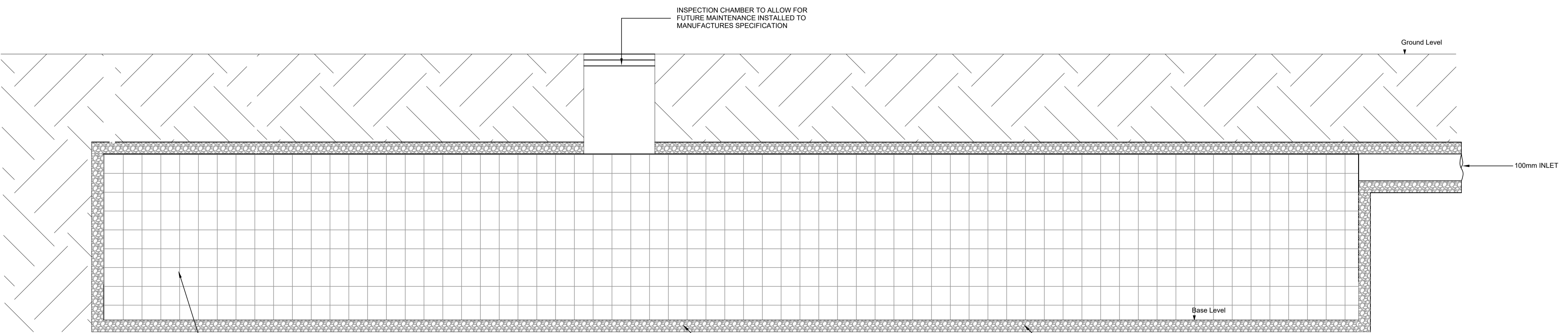

TYPICAL SECTION THROUGH SOAKAWAY STRUCTURE

REV	DESCRIPTION	BY	DATE
STATUS: PLANNING ISSUE			



Tel: 01902 475653
17 Goldthorn Avenue, Penn
Wolverhampton, WV4 5AA
www.onn-point.co.uk

CLIENT:	121 ELMLEAZE, LONGLEVENS GLOUCESTER, GL2		
SITE:	121 ELMLEAZE, LONGLEVENS GLOUCESTER, GL2		
TITLE:	DRAINAGE CONSTRUCTION DETAILS		
SCALE: AT A1:	DATE: 18.04.2022	DRAWN: RJS	CHECKED:
PROJECT NO:	DRAWING NO:	REVISION:	
22-OP-1217	A1/002	A	